

# Installation Manual

## E-SWN-PS+ - A2

### Standard Sensor

MFG number: B-H1NFP-J3



Halogen Systems  
8985 Double Diamond Pkwy  
Suite B10  
Reno, NV 89521  
Phone: +1 (775) 832-0495

## Critical Safety Information



### NOTICE

The manufacturer is not responsible for any damages due to misapplication or misuse of this product including, without limitation, direct, incidental and consequential damages, and disclaims such damages to the full extent permitted under applicable law. The user is solely responsible to identify critical application risks and install appropriate mechanisms to protect processes during a possible equipment malfunction.

Please read this entire manual before unpacking, setting up or operating this equipment. Pay attention to all danger and caution statements. Failure to do so could result in serious injury to the operator or damage to the equipment.

Make sure that the protection provided by this equipment is not impaired. Do not use or install this equipment in any manner other than that specified in this manual.

### Use of hazard information

	<b>DANGER</b>
Indicates a potentially or imminently hazardous situation which, if not avoided, will result in death or serious injury	
	<b>WARNING</b>
Indicates a potentially or imminently hazardous situation which, if not avoided, could result in death or serious injury.	
	<b>CAUTION</b>
Indicates a potentially hazardous situation that may result in minor or moderate injury.	

## Contents

1	Product Description.....	4
1.1	FEATURES .....	4
1.2	Measurement Ranges .....	4
1.3	SPECIFICATIONS.....	5
2	Sensor Installation.....	6
2.3	Standard Sensor (SWN-PS+CH) Chamber Installation.....	6
3	Cable Gland Installation Instructions .....	10
4	Limited Warranty .....	11

# 1 Product Description

The Sensor consists of the sensor probe, an optional hot tap mounting system, and an optional remote display unit.

## 1.1 FEATURES

- Measures TRO in samples having pH as high as 8.6
- Requires very little maintenance
- No membranes or electrolyte replacement required
- No waste stream or flow control
- Direct pipe insertion
- Self-cleaning

## 1.2 Measurement Ranges

Measurement	Range	Notes
TRO	0 to 15 ppm	Auto-ranging
ORP	-1100 to 1100 mV	
Conductivity	0 to 65,000 $\mu$ S	Auto-ranging
Temperature	0 to 100° C	

## 1.3 SPECIFICATIONS

### Sensor

#### Sample requirements:

Pressure: -0.7 to 10 Bar

Temperature: -5 (non-freezing) to 50° C

Minimum Flow: N/A

Maximum flow: 5 m/Sec

**Sample Salinity: 3 to 34 PSU** at 0 to 25°C

**Process connection: 3/8" OD tube connections**

#### Wetted parts:

Teflon, PVC, platinum, PEEK

pH sensor: PVC, Buna N, glass, Stainless Steel 316

**Response time to step change in TRO concentration:** <130 sec to 95% of final reading.

#### Weight/shipping weight:

Model SWN-P+: 3 kg

[rounded to the nearest 1 lb. (0.5 kg)]

**TRO range:** 0 to 15 ppm as Cl<sub>2</sub>. (0 to 15 ppm)

**Accuracy:** ±15% or 0.07 ppm, whichever is greater

**Sensor housing:** Stainless Steel 316

## 2 Sensor Installation



### **DANGER**

Multiple hazards. Only qualified personnel must conduct the tasks described in this section of the document. Make sure ballast pipe isolation valves are closed and the ballast pipe is drained before installation.

The two main components of the TRO System (chamber and sensor) must be mounted separately. The sensor is not affected by changes in flow rates.

### 2.3 Standard Sensor (SWN-PS+CH) Chamber Installation



**Figure 1: Exploded overview of sensor and chamber assembly**

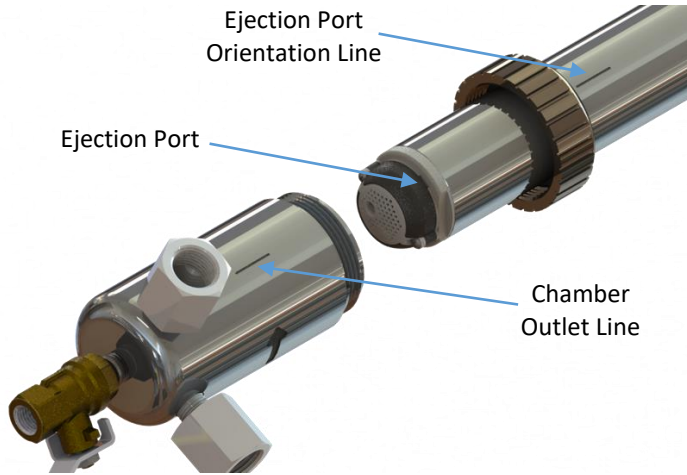

Figure 2: Sensor ejection port is identified by the engraved line on sensor sleeve. This line must be aligned with the engraved outlet line on the chamber during installation.

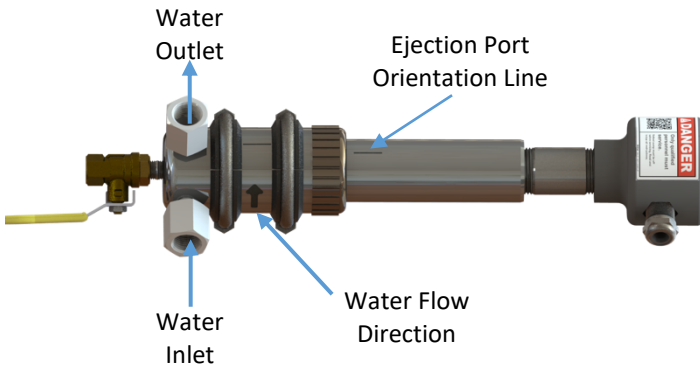

Figure 3: Optimize sensor operation by aligning the ejection port with the chamber water outlet.

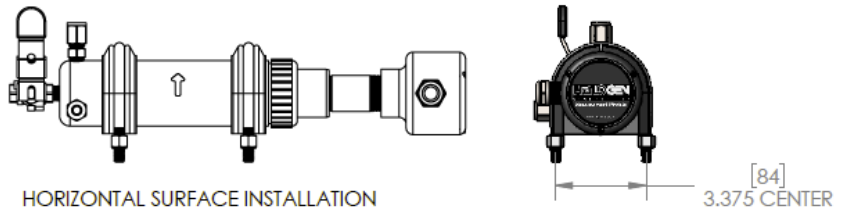

Figure 4: Chamber installation on a horizontal surface. Also shown is width between mounting holes.

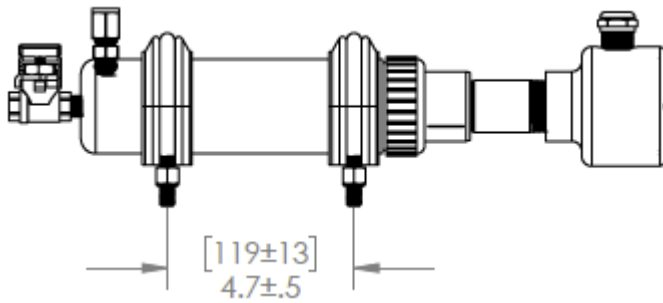

Figure 5: Distance between mounting holes- note brackets can be moved.

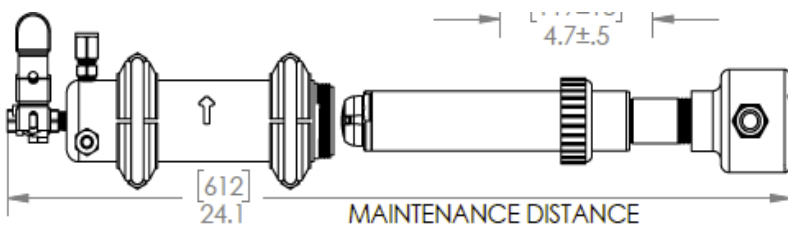

Figure 6: Required clearance distance for maintenance.



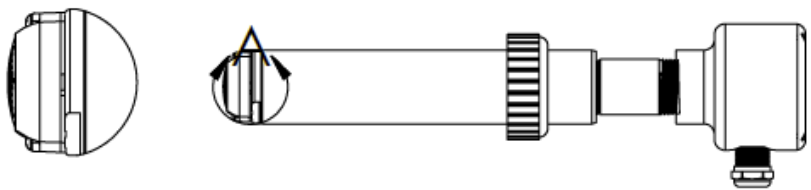

Figure 7: Outlet port orientation to ensure outlet port is "up" to purge air.

### 3 Cable Gland Installation Instructions

Ensure that there is a switch or disconnect to power down the system as necessary. It is recommended to use low voltage instrumentation cable with 4 conductors and braided shield such as Tricab 4c1mm2.

**Feed-Through (-FE)**

	<p><b>Option 1 - Partial Jacket Stripping:</b></p> <ul style="list-style-type: none"><li>• Expose shield approximately 7/16" (10 mm)</li><li>• Insert cable into fitting until the <b>foil or braid</b> reaches the contact position</li><li>• Tighten the dome nut</li><li>• Finished</li></ul>
	<p><b>Option 2 - Total Jacket Removed:</b></p> <ul style="list-style-type: none"><li>• Remove cable jacket to expose the braid or foil</li><li>• Insert cable into fitting until the braid reaches the contact point</li><li>• Tighten the dome nut</li><li>• Finished</li></ul>
	<p><b>Option 3 - Fold Shield over Jacket:</b></p> <ul style="list-style-type: none"><li>• Strip cable jacket &amp; braiding to different lengths</li><li>• For smaller cable diameters fold the braided shield back over the cable jacket</li><li>• Insert cable into fitting until the braid reaches the contact point</li><li>• Tighten the dome nut</li><li>• Finished</li></ul>

Figure 4: Cable Gland Installation Instructions

Sensor Module wiring note: the shield or external cable shield should contact the metal cable gland on the sensor module, which in turn, will provide contact to the metal sensor housing. If there is no external shield or armor, then the shield should be exposed on the cable by removing the outer insulation jacket (Cable gland on Sensor only). This procedure is described in Figure 6.

## 4 Limited Warranty

Halogen Systems warrants its products against material workmanship defects for a period of one year from the date of shipment

In the event a defect is discovered during the warranty period, Halogen Systems agrees, at its option, to repair or replace the defective product. Any product repaired or replaced under this warranty will be warranted only for the remainder of the original product warranty period.

Products may not be returned without authorization from Halogen Systems. To obtain authorization, please call Halogen Systems for a return material authorization number.

Limitations:

This warranty does not cover:

- 1) Damage caused by misuse, neglect (lack of appropriate maintenance), alteration, accident, or improper application or installation.
- 2) Damage caused by any repair or attempted repair not authorized by Halogen Systems.
- 3) Any product not used in accordance with the instructions furnished by Halogen Systems.
- 4) Damage caused by acts of God, natural disaster, acts of war (declared or undeclared), acts of terrorism, work actions, or acts of any governmental jurisdiction.
- 5) Freight charges to return merchandise to Halogen Systems.
- 6) Travel fees associated with on-site warranty repair.

This warranty is the sole expressed warranty made by Halogen Systems in connection with its product. All other warranties, whether expresses or implied, including without limitation, the

warranties of merchantability and fitness for a particular purpose, are expressly disclaimed.

The liability of Halogen Systems shall be limited to the cost of the item giving rise to the claim. In no event shall Halogen Systems be liable for incidental or consequential damages.

This warranty is the sole and complete warranty for Halogen Systems. No person is authorized to make any warranties or representations on behalf of Halogen Systems.

Halogen Systems reserves the right to change or modify this warranty at any time.