

# Operation and Maintenance Manual

OM01 R4.2.6

Models: SWN-P, SWN- P+, SWN-PS, SWN-PS+, EX-P-HT4, EX-P-STD, EX-P-STD2, SWN-P-HT2, SWN-P-HT2+, SWN-HT2+



## DECLARATION OF CONFORMITY

Tested to IM) MEPC 178(58) Part 3; LabTest Certification Inc. as per the requirements of USCG Federal Register 46 CFR part 162, subpart 162.060-30 and the DNV GL class guideline DNVGL-CG-0339 (August 2021), which incorporates the requirements of IACS UR E10.

All products listed below conform to the essential requirements set out in Restriction of use of certain Hazardous Substances Directive 2011/65/EU of 7 January 2011; Directive 2015/863 of 31 March 2015.



Manufacturer's Name: Halogen Systems, Inc.

Manufacturer's Address: 8985 Double Diamond Pkwy. Suite B10 Reno, NV, 89521

Type of Equipment: TRO Sensor

Model No: SWN-P, SWN- P+, SWN-PS, SWN-PS+, EX-P-HT4, EX-P-STD, EX-P-STD2, SWN-P-HT2, SWN-P-HT2+, SWN-HT2+, D01, D02, D04

I, the undersigned, hereby declare that the equipment specified above conforms to the above Directive and Standard.

Place: Incline Village, Nevada USA

A handwritten signature in black ink, appearing to read 'Michael Silveri'.

(Signature)

Date: February 23, 2023

Michael Silveri, President

## Critical Safety Information

### NOTICE

The manufacturer is not responsible for any damages due to misapplication or misuse of this product including, without limitation, direct, incidental and consequential damages, and disclaims such damages to the full extent permitted under applicable law. The user is solely responsible to identify critical application risks and install appropriate mechanisms to protect processes during a possible equipment malfunction.

Please read this entire manual before unpacking, setting up, or operating this equipment. Pay attention to all danger and caution statements. Failure to do so could result in serious injury to the operator or damage to the equipment.

Make sure that the protection provided by this equipment is not impaired. Do not use or install this equipment in any manner other than that specified in this manual.

#### Use of hazard information



### DANGER

Indicates a potentially or imminently hazardous situation which, if not avoided, will result in death or serious injury



### WARNING

Indicates a potentially or imminently hazardous situation which, if not avoided, could result in death or serious injury.



### CAUTION

Indicates a potentially hazardous situation that may result in minor or moderate injury.

# Contents

1	SPECIFICATIONS	5
2	START-UP AND OPERATION	6
3	MEANING OF INDICATORS	6
4	DISPLAY INTERFACE & KEY PAD OPERATION	7
5	CONFIGURATION	7
6	CALIBRATION	8
6.2	DILUTION PROCEDURE (SYSTEMS THAT USE MORE THAN 10 PPM TRO FOR BALLASTING)	12
7	CALIBRATE CHLORINE ZERO (USUALLY UNNECESSARY)	12
8	TROUBLESHOOTING	12
8.1	LEVEL ONE PROBLEM CODES AND ALARMS	12
8.2	LEVEL THREE ALARM CODES OUTSIDE MEASUREMENT RANGE	13
8.3	PH RELATED ERROR CODES (IF PH IS PRESENT SWN-PH-HT2)	14
8.4	LEVEL TWO PROBLEM CODES	14
8.5	DIAGNOSTICS	14
9	OUTPUT CONFIGURATION OPTIONS	15
9.1	TWO OUTPUT CONFIGURATION	15
9.2	4 OUTPUT CONFIGURATION	16
10	CHANGE MEASUREMENT OPTIONS	18
11	CHECKING THE LOG FILE	19
12	RESTORE DEFAULT CALIBRATIONS	20
13	CHANGING MODBUS OPTIONS	21
14	ADDITIONAL COMMANDS	21
14.1	LONG MENU	21
14.2	CALIBRATION KEY CODE	23
14.3	STOP FUNCTION	24
15	MANDATORY MAINTENANCE BY USER FOR SWN-P-HT2	24
16	MAINTENANCE COMPONENTS FOR ALL SWN- MODELS	24
17	BIANNUAL MAINTENANCE (SWN-P+/SWN-P-HT2+)	25
18	ANNUAL PH CALIBRATION CHECK	26
19	BIANNUAL REPLACEMENT OF WEAR PARTS ALL EXCEPT EX- MODELS	27
20	BIANNUAL PH SENSOR REPLACEMENT SWN-P-HT2+ AND SWN-P+	28
21	BIANNUAL CALIBRATE CONDUCTIVITY	29
22	LIMITED WARRANTY	30
23	REVISION HISTORY	31

# 1 SPECIFICATIONS

**Sensor housing:** Stainless Steel 316

**Chlorine Accuracy:**  $\pm 15\%$  or 0.06 ppm, whichever is greater Limit of Detection: 0.03 ppm

**Conductivity Range:** 150  $\mu\text{S}/\text{cm}$  to 60,000  $\mu\text{S}$

**Chlorine range:** 0 to 20.0 ppm as  $\text{Cl}_2$ .

**Response time:** 112 Seconds

**Process connection:** **SWN-P+** To be fitted in a 2-in NPT FIP Pipe Fitting (Tee)

## **Wetted parts:**

PVDF, PEEK, Stainless Steel 316

## **Weight/shipping weight:**

Model SWN-P, SWN-P(+)-HT2(+): 1.5 kg

Model EX-P-HT4: 2.5 kg.

(Rounded to the nearest 0.5 kg)

## **Sample requirements:**

Pressure: 0 to 10 Bar

Temperature:  $-2^\circ$  (non-freezing) to  $40^\circ\text{C}$

Minimum velocity: N/A

Maximum velocity: 5 m/s

Sample Salinity: 0.0 ( $>150\mu\text{S}/\text{cm}$ ) to 38 PSU at 0 to  $40^\circ\text{C}$ ; Note: the limit of 150  $\mu\text{S}/\text{cm}$  does not represent an practical salinity limitation for any BWMS. If freshwater with a salinity as low as 60  $\mu\text{S}/\text{cm}$  is treated by a BWMS using active substances, the ballast water will have a salinity higher than 150 – 200  $\mu\text{S}/\text{cm}$ .

pH: 6.5 to 9.0 (8.5 EX Models)

## **Electrical**

### **Communication**

RS485 between Sensor and Display: Max length of cable 1000 M (terminating resistor must be enabled in junction box)

4-20 mA Outputs (4): Max length of cable, 100 M (minimum impedance 100  $\Omega$ )

**Input Voltage:** 24VDC

**Input Current:** 350 mA

## 2 START-UP AND OPERATION

The start-up screen will appear after the first cycle (Figure 2). The display will take one minute to update. The system calibration should be checked at start and commissioning. If air is detected the sensor pump will cycle on and off three times to remove air from the sensor and may delay the first cycle completion by up to 20 seconds.

Main Screen																
C	H	L	-	-	-	-	-	n	A	-	-	-	-			
4	-	2	0	N	o	n	e	S	e	a	r	c	h	i	n	g

Indicates number for 4-20 mA Outputs are present

Figure 1: Start up screen shows the number of 4-20 mA Outputs (4) detected

Main Screen												
C	H	L	-	-	-	n	A	-	-	-	-	-
p	H	-	-	-	-	-	-	-	-	-	-	-
O	R	P	-	-	-	P	S	U	-	-	-	-
A	D	D	R	1	2	5	-	-	-	-	-	-

Sensor Modbus address

Figure 2: Main Screen: normal display after startup and signal found.

Main Screen														
C	H	L	0	.	1	7	n	A	1	7	7	E	O	C
p	H	7	.	4	0	-	-	-	-	-	-	-	-	-
O	R	P	8	0	3	P	S	U	3	2	-	-	-	-
T	e	m	p	1	8	-	-	-	-	-	-	-	-	-

nA = Sensor Current which is the signal strength and a useful troubleshooting tool

Figure 3: Display after start-up and complete sensor cycle of operation. Note the End of Cycle Indicator (EOC).

Figure 3 shows the “EOC” indicator on the LCD screen. This indicates the sensor is finished its measurement cycle and all measurements are updated on the screen. It will display this indicator for 1 second.

## 3 MEANING OF INDICATORS

**CHL:** Chlorine – This is the chlorine level in ppm (parts per million). The range is 0 to 20 ppm. The raw signal is in nanoamps of current and is proportional to the TRO level.

**ORP:** Oxidation Reduction Potential –This is another parameter that indicates the effectiveness of the TRO in killing organisms. Raw untreated seawater has an ORP of 180 to 280. This is used for diagnostics and can indicate the condition of the TRO electrode. It has a logarithmic relationship to TRO and is used for a qualitative comparison only. The reading is a voltage in millivolts.

**PSU:** Practical Salinity Units – A measurement unit of salinity i.e., the total amount of dissolved salts in water.

**CND:** Conductivity – can be selected instead of the PSU to be displayed on the screen and is a measure of the ability of the water to conduct electricity.

**T:** Temperature – in degrees C or F. It will also display below zero values.

## 4 DISPLAY INTERFACE & KEY PAD OPERATION



Figure 4: Display & Buttons

Key	Function Description
MENU	Displays the Menu Tree
SELECT	Accepts the value
→	Move Cursor Right
←	Move Cursor down
↕	Increment a digit or move cursor up
↕	Decrement a digit or mover cursor down
>	Cursor used to select items in a list
—	Cursor for digits- indicates digit that will be edited.
BACK	Moves one level back in Menu

## 5 CONFIGURATION

Press the **MENU** button and from the *Menu Screen* (Figure 5) select “Configuration”. From the *Configuration Screen* (Figure 6) select “4 – 20 mA range.” Use this screen to assign a full-scale chlorine concentration to the **20 mA** output. Use the **ARROW** buttons to change the maximum chlorine to the desired value. Press **SELECT** to store the setting. Edit the other settings as necessary in a similar manner.

Chlorine is on 4-20 mA Output 1

Output is set to PSU by default. To change this, see Section 9 Output Configuration Options

**Note:** Standard Display units (D01) have two 4-20 mA outputs. D04 has 4 outputs (see Figure 7).

C	O	N	F	I	G	U	R	A	T	I	O	N							
>	C	A	L	I	B	R	A	T	E										
	D	I	A	G	N	O	S	T	I	C	S								

Figure 5: Menu Screen

	M	e	a	u	r	e	m	e	n	t		O	p	t	i	o	n	s	
>	4	-	2	0	M	A		O	p	t	i	o	n	s					
	M	o	d	b	u	s													

Figure 6: Configuration Screen

>	S	E	T		4	-	2	0	M	A		R	A	N	G	E			
	S	e	l	e	c	t		O	u	t	2		T	y	p	e			
	S	e	t		4	-	2	0	M	A		O	f	f	s	e	t		
	D	i	s	p		T	e	m	p		F					N	O		

Figure 7: Set 4 - 20 mA

Set 4-20 mA 4 Channel Range																			
	4	-	2	0		M	A		C	H	L					1	0	.	0
	4	-	2	0		M	A		P	S	U					5	0	.	0
>	4	-	2	0		M	A		T	E	M	P				4	0	.	0
	4	-	2	0		M	A		P	H						7	.	0	

## 6 CALIBRATION

We recommend the use of the Hach Pocket Colorimeter.

<https://www.hach.com/product.detail-overview.jsa?seoTerm=dr300-pocket-colorimeter-chlorine-free-total-with-box&id=55321383862>

- See Procedure for high range <https://www.hach.com/asset-get.download.jsa?id=31948984050>
- See Procedure for low range <https://www.hach.com/asset-get.download.jsa?id=31948984021>

We recommend that calibration be checked as follows:

- (1) Check calibration at least every six months.
- (2) If the value deviates by more than 20% then sensor recalibrate.
- (3) Calibration can be checked using a Colorimeter.
- (4) Calibration is usually not required for 12 months or more.

### Low Level Calibration-

**There are two Calibration Levels: Low and High. Both are independently set. The first step is to calibrate the high level. If the low level is not accurate, then it can be calibrated separately.**

1. The high-level chlorine level for calibration must be between 1 and 20 ppm.



2. The low-level chlorine level must be between 0.2 and 0.7 ppm.
3. If you perform the low range calibration you should perform a zero-chlorine calibration before performing the low range calibration.

The Sensor will automatically select the low calibration if the known levels are within the range listed in 2 (above). It will select the high range calibration if the levels match those listed in 1 (above). The steps below are for the high range calibration. To calibrate the low range, repeat the steps for the low range.

To check calibration, follow the steps below:

Note: for convenience, steps for the high range measurement are listed here. Complete procedure is available using the links above under Calibration.

## Prepare DPD Blank

To calibrate chlorine sensor to known chlorine level: **Prepare the instrument with a zero (blank value).**



**1. Set the instrument to high range (HR).**  
For DR300, push the up arrow button. For PCII, push the menu button, checkmark button, then the menu button again.



**2. Prepare the blank:**  
Rinse a 1-cm/10-mL sample cell and cap three times with sample. Fill the sample cell to the 5-mL mark with sample. Close the sample cell.



**3. Clean the blank sample cell.**



**4. Insert the blank into the cell holder. Point the triangle mark on the sample cell away from the keypad.**

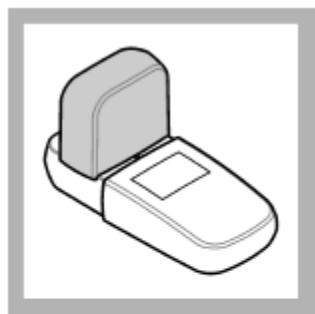

**5. Install the instrument cap over the cell holder.**



**6. Push ZERO. The display shows "0.0".**



**7. Remove the sample cell from the cell holder.**

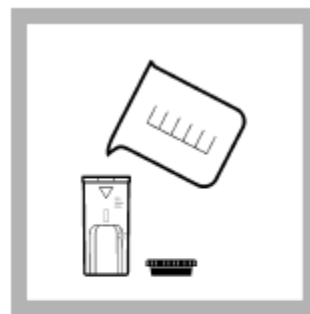

**8. Prepare the sample:**  
Rinse a second 1-cm/10-mL sample cell and cap three times with sample. Fill the sample cell to the 5-mL mark with sample.

## Start Calibration Cycle

If Chlorine levels are generally stable during ballasting, use the Fast Calibration Method. If levels are changing rapidly, use the time delay calibration in the CALIBRATE menu function. The sequence differs slightly and will be described below.

The sensor should be calibrated in water with a chlorine level between 2 and 20 ppm and low levels between 0.2 and 0.7 ppm.

## Fast Calibration

This method can be used by most BWMS systems that inject oxidant during ballasting.

Determine the chlorine level in Section *DPD Reading* (below)

Once you have obtained the reading, perform this sequence.

### MENU | Calibration | Chlorine Menu | Fast CHL Cal

<p>Press Select. This will store the sensor value for up to 5 minutes until the DPD level is obtained.</p>	<table border="1"> <thead> <tr> <th colspan="10">CHL Menu</th> </tr> </thead> <tbody> <tr> <td>&gt;</td><td>K</td><td>N</td><td>O</td><td>W</td><td>N</td><td>L</td><td>E</td><td>V</td><td>E</td><td>L</td> </tr> <tr> <td></td><td>C</td><td>H</td><td>L</td><td>Z</td><td>E</td><td>R</td><td>O</td><td></td><td>D</td><td>O</td><td>N</td><td>E</td> </tr> <tr> <td></td><td>F</td><td>a</td><td>s</td><td>t</td><td>C</td><td>H</td><td>L</td><td>C</td><td>a</td><td>l</td> </tr> <tr> <td></td><td>R</td><td>e</td><td>s</td><td>t</td><td>o</td><td>r</td><td>e</td><td>D</td><td>e</td><td>f</td><td>a</td><td>u</td><td>l</td><td>t</td><td>C</td><td>a</td><td>l</td> </tr> </tbody> </table>	CHL Menu										>	K	N	O	W	N	L	E	V	E	L		C	H	L	Z	E	R	O		D	O	N	E		F	a	s	t	C	H	L	C	a	l		R	e	s	t	o	r	e	D	e	f	a	u	l	t	C	a	l
CHL Menu																																																																
>	K	N	O	W	N	L	E	V	E	L																																																						
	C	H	L	Z	E	R	O		D	O	N	E																																																				
	F	a	s	t	C	H	L	C	a	l																																																						
	R	e	s	t	o	r	e	D	e	f	a	u	l	t	C	a	l																																															
<p>The cursor will appear below the first digit. Use the arrow keys to select and increment the digit to match the reading to the DPD value. Use the → button to select which digit to change to match DPD value and the ↑ ↓ buttons to change the value, and press <b>SELECT</b> to complete.</p>	<table border="1"> <tbody> <tr> <td>&gt;</td><td>A</td><td>d</td><td>j</td><td>u</td><td>s</td><td>t</td><td>C</td><td>H</td><td>L</td><td></td><td></td><td></td><td></td><td></td><td></td><td></td><td></td><td>6</td><td>.</td><td>5</td><td>5</td> </tr> </tbody> </table>	>	A	d	j	u	s	t	C	H	L									6	.	5	5																																									
>	A	d	j	u	s	t	C	H	L									6	.	5	5																																											

## CALIBRATION (10 Minute Time Delay)

This method will store the internal signal value for chlorine in the Display for up to 10 minutes. This will allow time after pulling the water sample for the DPD reaction time (3 minutes). The stored signal value will be used for the calibration of the sensor. This is useful for a system using an in tank BWMS method.

<p>Navigate to the <b>CHL Menu</b></p>	<p><b>Menu   Calibration   CHL Menu</b></p>																																																					
<p>Select <b>Known Level</b>.</p>	<table border="1"> <tbody> <tr> <td>&gt;</td><td>K</td><td>N</td><td>O</td><td>W</td><td>N</td><td>L</td><td>E</td><td>V</td><td>E</td><td>L</td> </tr> <tr> <td></td><td>C</td><td>H</td><td>L</td><td>Z</td><td>E</td><td>R</td><td>O</td><td></td><td>D</td><td>O</td><td>N</td><td>E</td> </tr> <tr> <td></td><td>F</td><td>a</td><td>s</td><td>t</td><td>C</td><td>H</td><td>L</td><td>C</td><td>a</td><td>l</td> </tr> <tr> <td></td><td>R</td><td>e</td><td>s</td><td>t</td><td>o</td><td>r</td><td>e</td><td>D</td><td>e</td><td>f</td><td>a</td><td>u</td><td>l</td><td>t</td><td>C</td><td>a</td><td>l</td> </tr> </tbody> </table>	>	K	N	O	W	N	L	E	V	E	L		C	H	L	Z	E	R	O		D	O	N	E		F	a	s	t	C	H	L	C	a	l		R	e	s	t	o	r	e	D	e	f	a	u	l	t	C	a	l
>	K	N	O	W	N	L	E	V	E	L																																												
	C	H	L	Z	E	R	O		D	O	N	E																																										
	F	a	s	t	C	H	L	C	a	l																																												
	R	e	s	t	o	r	e	D	e	f	a	u	l	t	C	a	l																																					
<p>When you have pulled the sample, select <b>TAKE SAMPLE</b>. This will start the 10-minute timer and store the signal value.</p>	<table border="1"> <tbody> <tr> <td>&gt;</td><td>T</td><td>A</td><td>K</td><td>E</td><td>S</td><td>A</td><td>M</td><td>P</td><td>L</td><td>E</td><td>1</td><td>0</td><td>M</td><td>I</td><td>N</td> </tr> <tr> <td></td><td>D</td><td>P</td><td>D</td><td>L</td><td>E</td><td>V</td><td>E</td><td>L</td><td></td><td></td><td>0</td><td>8</td><td>.</td><td>9</td><td>7</td> </tr> </tbody> </table>	>	T	A	K	E	S	A	M	P	L	E	1	0	M	I	N		D	P	D	L	E	V	E	L			0	8	.	9	7																					
>	T	A	K	E	S	A	M	P	L	E	1	0	M	I	N																																							
	D	P	D	L	E	V	E	L			0	8	.	9	7																																							
<p>Perform the DPD Reading in DPD Section after obtaining the value Select DPD LEVEL. The cursor will appear below the first digit. Use the arrow keys to select and increment the digit to match the reading to the DPD value. Use the → button to select which digit to change to match DPD value and the ↑ ↓ buttons to change the value, and press <b>SELECT</b> to complete.</p>	<table border="1"> <tbody> <tr> <td></td><td>T</td><td>i</td><td>m</td><td>e</td><td>9</td><td>.</td><td>3</td><td>M</td><td>I</td><td>N</td><td>R</td><td>e</td><td>m</td><td>a</td><td>i</td><td>n</td> </tr> <tr> <td>&gt;</td><td>D</td><td>P</td><td>D</td><td>L</td><td>E</td><td>V</td><td>E</td><td>L</td><td></td><td></td><td>0</td><td>8</td><td>.</td><td>9</td><td>7</td> </tr> <tr> <td></td><td>S</td><td>a</td><td>v</td><td>e</td><td>N</td><td>o</td><td>w</td> </tr> </tbody> </table>		T	i	m	e	9	.	3	M	I	N	R	e	m	a	i	n	>	D	P	D	L	E	V	E	L			0	8	.	9	7		S	a	v	e	N	o	w												
	T	i	m	e	9	.	3	M	I	N	R	e	m	a	i	n																																						
>	D	P	D	L	E	V	E	L			0	8	.	9	7																																							
	S	a	v	e	N	o	w																																															

<p>Move the cursor to <b>Save Now</b> and press <b>SELECT</b>. The following screen will appear.</p>	<table border="1"> <tr><td>-</td><td>-</td><td>-</td><td>-</td><td>-</td><td>-</td><td>-</td><td>-</td><td>-</td><td>-</td><td>-</td><td>-</td><td>-</td><td>-</td><td>-</td><td>-</td><td>-</td><td>-</td><td>-</td><td>-</td></tr> <tr><td colspan="19">N O T E :</td></tr> <tr><td>C</td><td>a</td><td>l</td><td>t</td><td>a</td><td>k</td><td>e</td><td>s</td><td> </td><td>m</td><td>a</td><td>n</td><td>y</td><td> </td><td>m</td><td>i</td><td>n</td><td>s</td><td> </td><td></td></tr> <tr><td>-</td><td>-</td><td>-</td><td>-</td><td>-</td><td>-</td><td>-</td><td>-</td><td>-</td><td>-</td><td>-</td><td>-</td><td>-</td><td>-</td><td>-</td><td>-</td><td>-</td><td>-</td><td>-</td><td>-</td></tr> </table>	-	-	-	-	-	-	-	-	-	-	-	-	-	-	-	-	-	-	-	-	N O T E :																			C	a	l	t	a	k	e	s		m	a	n	y		m	i	n	s			-	-	-	-	-	-	-	-	-	-	-	-	-	-	-	-	-	-	-	-
-	-	-	-	-	-	-	-	-	-	-	-	-	-	-	-	-	-	-	-																																																													
N O T E :																																																																																
C	a	l	t	a	k	e	s		m	a	n	y		m	i	n	s																																																															
-	-	-	-	-	-	-	-	-	-	-	-	-	-	-	-	-	-	-	-																																																													
<p>Once the calibration has been saved, the display will return to the main screen.</p>	<table border="1"> <tr><td>C</td><td>H</td><td>L</td><td> </td><td>8</td><td>.</td><td>9</td><td>7</td><td> </td><td> </td><td> </td><td> </td><td>n</td><td>A</td><td> </td><td>9</td><td>1</td><td>5</td><td>6</td></tr> <tr><td>p</td><td>H</td><td> </td><td> </td><td>7</td><td>.</td><td>4</td><td>0</td><td> </td><td> </td><td> </td><td> </td><td> </td><td> </td><td> </td><td> </td><td> </td><td> </td><td> </td></tr> <tr><td>O</td><td>R</td><td>P</td><td> </td><td>8</td><td>0</td><td>3</td><td> </td><td> </td><td> </td><td>P</td><td>S</td><td>U</td><td> </td><td> </td><td>3</td><td>2</td><td> </td><td> </td></tr> <tr><td>T</td><td>e</td><td>m</td><td>p</td><td> </td><td> </td><td>1</td><td>8</td><td> </td><td> </td><td> </td><td> </td><td> </td><td> </td><td> </td><td> </td><td> </td><td> </td><td> </td></tr> </table>	C	H	L		8	.	9	7					n	A		9	1	5	6	p	H			7	.	4	0												O	R	P		8	0	3				P	S	U			3	2			T	e	m	p			1	8														
C	H	L		8	.	9	7					n	A		9	1	5	6																																																														
p	H			7	.	4	0																																																																									
O	R	P		8	0	3				P	S	U			3	2																																																																
T	e	m	p			1	8																																																																									

## DPD Reading

Collect the water sample. Be sure to open the sample port long enough to obtain a representative sample. This may require many seconds depending on flowrate. Rinse both the container used to capture the sample and colorimeter cell with the sample water several times.



**9.** Add two 10-mL DPD Free Chlorine Reagent Powder Pillows or two 10-mL DPD Total Chlorine Reagent Powder Pillows to the second sample cell.

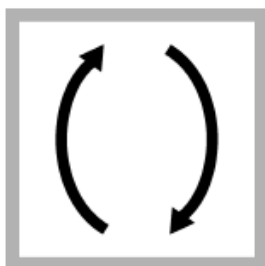

**10.** Close the sample cell. Invert the sample cell for about **20 seconds** to dissolve the reagent. Undissolved powder will not affect accuracy. A pink color will show if chlorine is in the sample.



**11.** Clean the prepared sample cell.



**12. Free chlorine measurement:** Within 1 minute of the reagent addition, insert the prepared sample into the cell holder. Point the triangle mark on the sample cell away from the keypad. Go to step 15.



**13.** Set and start a timer for 3 minutes. A 3-minute reaction time starts.



**14. Total chlorine measurement:** After 3 minutes and within 6 minutes of the reagent addition, insert the prepared sample into the cell holder. Point the triangle mark on the sample cell away from the keypad.

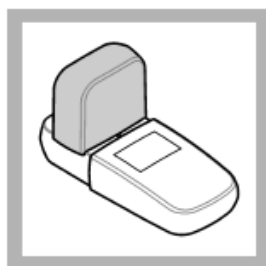

**15.** Install the instrument cap over the cell holder.



**16.** Push **READ**. Results show in mg/L chlorine (Cl<sub>2</sub>).

**Note:** After calibration, a new value will display on the next cycle, ~1 minute.

## 6.2 DILUTION PROCEDURE (SYSTEMS THAT USE MORE THAN 10 PPM TRO FOR BALLASTING)

- Follow Step 1 above to fill cuvette with sample.
- Fill a second vial with water without TRO (Deionized water is OK) twice.
- Pour both cuvette into the supplied 50 mL bottle and mix by inverting.
- Resume testing in Step 1 above.
- Multiply the result by 3 for TRO level.

## 7 CALIBRATE CHLORINE ZERO (USUALLY UNNECESSARY)

**MENU | Calibrate | CHL Menu | Chl Zero**

Press SELECT for each Menu Option

The cursor will move to “Done” and the chlorine zero has been set.

*Be certain that there is no chlorine residual before performing this operation.*

## 8 TROUBLESHOOTING

*Display “ADDR None Searching”*

This indicates that the display is not communicating with the sensor module.

- Check the connection and wiring to the Sensor Module for loose or swapped connections.
- After correcting the problem, power the display off and back on.
- Check the sensor to see if the motor is working.
  - If not, power and ground lines may be wired backwards. Check and correct.
- There could be a short in the wiring to the sensor.
- Check all four wires resistance to ground (sensor housing) with an Ohm Meter.
  - There could be an internal short from the wires to the sensor from the time the valve adapter was added. Resistance should be open (infinite resistance).
  - If the motor is working, the com lines may be reversed. Check and correct.
- If the sensor still does not communicate, then replace it with a new sensor.

-	-	-	-	-	-	-	-	-	-	-	-	-	-	-	-	-	-
E	r	r	o	r	:												
S	e	n	s	o	r		N	o	t		F	o	u	n	d		
-	-	-	-	-	-	-	-	-	-	-	-	-	-	-	-	-	-

Figure 8: Screen indicates no communication with sensor- no sensor address found

### 8.1 LEVEL ONE PROBLEM CODES AND ALARMS

If an error occurs with the sensor, it will be displayed in the lower right corner of the *Main Screen* (Figure).

Main Screen																	
C	H	L		0.	1	7							n	A	1	7	7
p	H			7.	4	0							P	S	U	3	2
O	R	P		8	0	3							C	N	D	4	8
T				1	8.	0		1	2	5						E	R
																1	5

Figure 9: Error displayed on Main Screen

<b>Level One Fault Codes (Firmware 3.31 and higher)</b>			
These problems will still allow operation of the measurement module and will be cleared when the condition is removed or corrected.			
<b>Error Code</b>	<b>Meaning</b>	<b>Cause</b>	<b>Corrective Action</b>
1	Air in Sensor	Possible air in sensor, open wire connection, or bad sensor.	Power on and off to prime sensor. Check installation to ensure outlet port is vertical or perpendicular to flow. Check orientation: should be mounted 90° to 270°. If problem persists for five resets, replace sensor with exchange unit.
31	Air in Sensor	Air in sensor. The sensor will enter a priming function and try to remove the air. Error will clear automatically when condition is corrected.	Power on and off several times. Make sure sensor is immersed in water. Check Sensor orientation.
33	Motor Locked	Debris in sensor cover.	Check for debris in sensor cover. See Section 18 for sensor disassembly.
35	Motor RPM very Low	Debris in sensor or corroded impeller or worn bearings (error code only present in firmware versions earlier than 396).	Check for debris in sensor cover. See Section 18 for sensor disassembly. Replace impeller and bearings if worn or corroded.
87	Bad temp Cal	Temperature Cal out of range or too low to calibrate	Replace sensor with exchange unit.
13	Zero calibration out of range	Zero calibration out of range.	Reset zero calibration to zero.

## 8.2 LEVEL THREE ALARM CODES OUTSIDE MEASUREMENT RANGE

These errors will cause the Display to flash the backlight and the 4-20 mA output to go negative (<4 mA output). These conditions are outside of the Sensor's operating parameters indicating the displayed results may not be accurate.

<b>Outside Measurement Range Alarms (Firmware v490 and higher Display v199 and higher)</b>			
These problems will still allow operation of the Sensor and will be cleared when the condition is removed or corrected.			
<b>Error Code</b>	<b>Meaning</b>	<b>Cause</b>	<b>Corrective Action</b>
36	Chlorine level exceeds measuring range >30 ppm	Process chlorine level to high- may be inaccurate.	Check process. Replace sensor if TRO level is not accurate.
37	pH low <5	Verify pH with handheld meter.	If sensor is not accurate, replace the pH sensor.
38	pH high >10	Verify pH with handheld meter.	If sensor is not accurate, replace the pH sensor.
39	Conductivity high >65,000 µS	Check sensor operation.	Verify conductivity level and replace sensor with exchange unit if necessary.
40	Temperature high >42°C	Check accuracy of measurement.	If temperature is accurate, reduce process temperature.

### 8.3 PH RELATED ERROR CODES (IF PH IS PRESENT SWN-PH-HT2)

15	pH reading out of range	pH sensor bad. System set with pH option but no pH installed.	Replace pH sensor Turn off pH measurement option.
16	Bad offset	pH zero not in manufacturer specified range.	Replace pH sensor.
17	Bad pH slope	pH slope not in manufacturer specified range.	Replace pH sensor.

### 8.4 LEVEL TWO PROBLEM CODES

These types of faults, detected by the system, stop the cycle pending removal or correction of the condition.

These errors will generate an alarm condition that will cause the Display to flash the backlight and the 4-20 mA output to go negative (<4 mA output).

Level Two Error Codes			
These problem codes will stop the cycling of the measurement module until corrected.			
Error Code	Message	Cause	Corrective Action
10	Sensor communication problem	Sensor not responding or missing, no communications with the temperature sensor board.	Check sensor connections. Replace sensor with exchange unit.

### 8.5 DIAGNOSTICS

Beginning with version 2.08 of the Display Firmware, the following simplified procedure will bring up important operation information. For Technical Support, please take a photo of this screen. To display this screen, press the DOWN Arrow button ↓ from the main display. This will bring up the screen below:

Down Arrow From Main Screen														
N a		1	1	4	4			A U X		1	1	5	7	m V
C L Z	0					C L S	1	0	0	0				
M S	2	2	0	8		P H Z	1	0	0	P H S	-	4	5	0
V M	6	9	9		D	2	2	7		E R R	0.	0.		

Below is a description of what each of the values refers to. This will be useful for technical support.

Legend for display locations		
Sensor Current		Aux Voltage
Chlorine zero calibration value		Chlorine slope calibration value
Motor Speed	pH Zero calibration value	pH Slope calibration value
Version Sensor	Version Display	Last Errors

*To Check Sensor Readings*

To check the sensor measurement readings follow the key press sequence below to see the measurement values of a reading. This is also useful for technical support and is used with Display Firmware versions 2.07 and lower.

**MENU | Diagnostics | Monitor | Meas Readings**

1	6	2	4	N	a	A	U	X	1	1	5	7	m	V		
I	2	V	2	5	0	M	T	R	2	0	9	3				
A	D	1	0	2	7	0	F	L	T	0	0	0	0	0	0	0
V	e	r	M	3	0	1	V	e	r	D	1	7	7			

Motor Speed

Last Error Codes

Figure 10: Measure Readings Screen

VMXXX = Sensor Firmware Version (3.01)

DXXX = Display Firmware Version (1.77)

**9 OUTPUT CONFIGURATION OPTIONS**

4-20 mA Output 2 can be configured for either PSU (default), pH, or ORP. See screens below to select it. The bottom line of the display indicates which output is selected.

**9.1 TWO OUTPUT CONFIGURATION**

M	e	a	u	r	e	m	e	n	t	O	p	t	i	o	n	s
>	4	-	2	0	M	A	O	p	t	i	o	n	s			
M	o	d	b	u	s											

Figure 91 Select Output2 Type

<b>Set 4-20 mA Output 2 Channel</b>																	
S	e	l	e	c	t	P	S	U									
S	e	l	e	c	t	P	H										
S	e	l	e	c	t	O	R	P									
>	S	e	l	e	c	t	C	N	D	O	U	T	2	=	C	N	D

Figure 102: Options available for Output 2 Channel

<b>Set 4-20 mA</b>																		
4	-	2	0	M	A	C	H	L						1	0	.	0	
4	-	2	0	M	A	P	S	U						5	0	.	0	
4	-	2	0	M	A	T	E	M	P					5	0	.	0	
4	-	2	0	M	A	P	H							1	2	.	0	
4	-	2	0	M	A	O	R	P						2	0		0	
>	4	-	2	0	M	A	C	O	N	D				6	5	0	0	0

Figure 113: When setting output to from PSU to Cond, the label will not change to Cond even the 4-20 will be set for this output. Be sure to adjust the high level to max conductivity level.

Scroll down to reach the ORP and CND lines. Adjust CND to 65000.

**Set 4-20 mA 4 Channel**

	4	-	2	0	M	A	O	R	P				2	0	0		
>	4	-	2	0	M	A	C	N	D				6	5	0	0	0

**9.2 4 OUTPUT CONFIGURATION**

*pH Output (4 Output Display)*

pH 4-20 mA output can be configured for different output options. Some common examples are:

1. pH 5 to 12 (default)
2. pH 0 to 14

Offset is set to the lower pH limit. For case 1 it will be set to 5. Case 2 will be 0.

4-20 mA Range is set to upper limit minus the Offset. Case 1 will be 12 – 5 = 7. Case 2 will be 14 - 0 = 14

*Temperature Output (Change to °F)*

- The 4-20 mA Output for Temperature can be configured from °C to °F on the 4-20 mA Output. To change the display see Measurement Options menu and make this change there. The two settings are independent of each other.
- Then configure the 4-20 mA output as follows:
  - OFFSET is the minimum temperature for the 4-20 mA output span
  - RANGE is the span less the OFFSET

*Example: Set 4-20 mA Span from 32°F to 122°F*

1. Set Disp Temp to F

**Configuration with 4-20 mA Outputs**

S	E	T	4	-	2	0	M	A	R	A	N	G	E		
S	e	l	e	c	t	O	u	t	2	T	y	p			
S	e	t	4	-	2	0	O	f	s	e	t				
D	i	s	p	T	e	m	p	F					Y	E	S

2. Set OFFSET or minimum temperature of 32°F will be OFFSET 032

**Set 4-20 mA Offset (°F = YES)**

4	-	2	0	M	A	T	E	M	P				0	3	2	
4	-	2	0	M	A	P	H						5	.	0	

Figure 124: Temperature Offset to °F

3. Set Range to (122-32 =90) 090



**Set 4-20 mA 4 Channel**

4 -	2 0	MA	C H L					1 0 . 0
4 -	2 0	MA	P S U					5 0 . 0
>	4 -	2 0	MA	T E M P				9 0 . 0
4 -	2 0	MA	P H					7 . 0

Figure 135: change Temperature range

Example: Set 4-20 mA Span from 0°C to 40°C

1. Set Disp Temp to C (select Down to No)

**Configuration with 4-20 mA Outputs**

S E T	4 -	2 0	MA	R A N G E				
S e l e c t	O u t	2	T y p					
S e t	4 -	2 0	O f s e t					
D i s p	T e m p	F						N O

Figure 146: Set to Output °C

2. Set OFFSET or minimum temperature of 0°C will be OFFSET 00.0

**Set 4-20 mA Offset (°F = NO)**

4 -	2 0	MA	T E M P					- 0 0 . 0
4 -	2 0	MA	P H					5 . 0

Figure 157: Temperature Offset to °F

3. Set Range to (40-0 =40) 040

**Set 4-20 mA 4 Channel Range**

4 -	2 0	MA	C H L					1 0 . 0
4 -	2 0	MA	P S U					5 0 . 0
>	4 -	2 0	MA	T E M P				4 0 . 0
4 -	2 0	MA	P H					7 . 0

Figure 168: Set Range for temperature to 40°C

**9.3 4-20 mA CALIBRATION**

\*Only applicable to 4 channel 4-20 mA output displays.

Navigate to the 4-20 mA Calibration Menu:

**Menu | Calibration | 4-20**

Utilize the below menu screen to calibrate 4-20 mA outputs:

4-20 Calibration Menu												
>	4	-	20	o	u	t						2
	S	e	t	o	u	t	=	4	m	A		
	A	d	j	4	m	a	D	A	C		4	.00
	A	d	j	20	m	a	D	A	C		20	.00

1. Select output to calibrate (2, 3, or 4) using the up and down arrows.
2. Connect an ammeter to output leads to read the live current of the output to be calibrated.
3. Set display output to 4 mA by hitting select on **Set out =** until it reads **4mA**.
  - a. The display will start sending the 4-mA signal after selection.
4. Select **Adj 4 ma DAC**. Value will be 4.00 prior to calibration.
5. Adjust value up or down to calibrate value to the ammeter measurement.
6. After adjusting value, press **Select** to store the calibration value.
7. Scroll up to **Set Out** and press **Select** to set display output to 20 mA.
  - a. The display will start sending the 20-mA signal after selection.
8. Select **Adj 20 mA DAC**. Value will be 20.00 prior to calibration.

4-20 Calibration Menu												
	4	-	20	o	u	t						2
>	S	e	t	o	u	t	=	20	m	A		
	A	d	j	4	m	a	D	A	C		3	.97
	A	d	j	20	m	a	D	A	C		20	.00

9. Adjust value up or down to calibrate value to the ammeter measurement.
10. After adjusting value, press **Select** to store the calibration value.
11. If calibrating multiple outputs, start from step 1 and select a different output channel.
12. Exiting the 4-20 menu will save calibrations and revert to normal 4-20mA output measurement options.

## 10 CHANGE MEASUREMENT OPTIONS

MENU | Configuration | Measurement Options

Configuration																	
>	M	e	a	u	r	e	m	e	n	t	O	p	t	i	o	n	s
	4	-	20	M	A	R	a	n	g	e							
	M	o	d	b	u	s											

Figure 19: Measurement Options

pH and ORP can be turned off. Warning: pH should not be turned off if a pH sensor is present. This is only used with SWN-P models (that do not have a pH sensor is present). To stop pH from displaying on main screen disable Dsp pH (no X).

The display of Conductivity, PSU and pH can be turned off. Turn off CND to display PSU. Deg F enables °F Temperature unit display.

Options													
D	o	p	H			X	D	s	p	C	N	D	X
D	o	O	R	P		X	D	s	p	P	S	U	X
D	s	p	p	H		X	D	e	g	F			X
D	s	p	O	R	P	X	D	o		P	S		X

Options Page 2 (without Long Menu Active)													
D	s	p	.	0	1	X		N	/	A			
E	O	C	H	I	d	-		N	/	A			
N	/	A						N	/	A			
N	/	A						N	/	A			

Figure 20: Select item to enable or disable

To enable 0.00 precision on the chlorine reading (0.01), scroll down to the Dsp .01 and put an X next to this measurement.

If Conductivity is enabled, PSU will not display on Main Screen, only the conductivity value.

Main Screen												
C	H	L	0.	1	7			n	A	1	7	7
p	H	7.	4	0								
O	R	P	8	0	3		P	S	U	0		
T	1	8	1	2	5							

Figure 21: Display with PSU enabled and CND disabled

## 11 CHECKING THE LOG FILE

If errors are encountered during operation, it is sometimes useful to view the log file entries. Log file entries are not timestamped but are recorded continuously in a loop. There is a maximum of 65,000 entries. The last log entries appear first. To view the logs press MENU | Diagnostics | Log | View Last Log.

Log File													
	M	o	n	i	t	o	r						
>	L	o	g										

Log File													
>	V	i	e	w	L	a	s	t	L	o	g		
	E	r	a	s	e	L	o	g	s				
T	o	t	a	l	L	o	g	s	2	5	6	2	7

A sample log entry is shown below: See the table for detail of what each item means.

Log File																	
L	o	g	1	9	5			C	H	L	5	.	0	0			
p	H	7	.	8	5	n	A	2	3	0	4	0					
C	N	D	4	5	0	0	0	T	1	9	8	O	R	P	6	5	0
E	r	r	0	0	A	U	X	1	1	9	8	M	T	2	2	0	8

Log File Entry Meanings		
Log	The number of the log being displayed.	
CHL	The chlorine level displayed.	
pH	pH reading.	This is generally not displayed unless enabled in the firmware.
nA	The current (signal) for the chlorine reading.	
CND	Conductivity.	Can be converted to PSU.
T	Temperature reading (decimal not shown).	
ORP	Oxidation Reduction Potential (if enabled in Configuration).	
Err	Error Code.	See Troubleshooting section.
AUX	Indicates if air is present.	Values about 2100 are usually due to air. Can also indicate a chlorine sensor problem.
Mt	Motor speed.	If intermittently zero could indicate air.

## 12 RESTORE DEFAULT CALIBRATIONS

If the sensor settings and calibrations have been changed and the sensor is not measuring correctly or has persistent error codes that cannot be resolved, then restoring the default calibrations may resolve the issue. \*\*Note: If you restore calibration to defaults, you will need to re-calibrate the sensor for chlorine and/or pH.

With the Long Menu active (Section 14) navigate:

**MENU | Diagnostics | Calibration/Default | Set to Defaults | Cals to default**

Diagnostics																					
M	o	n	i	t	o	r															
>	C	a	l	i	b	r	a	t	i	o	n	/	D	e	f	a	u	l	t		
	L	o	g																		

Calibration/Defaults																						
S	e	t		P	H	/	C	H	L	/	C	O	N	D								
>	S	e	t		t	o		D	e	f	a	u	l	t	s							

Set to Defaults																						
>	C	a	l	s		t	o		d	e	f	a	u	l	t							

Figure 22: Restoring default calibrations.

### 13 CHANGING MODBUS OPTIONS

MENU | Configuration | Modbus

These options can be used to reset the Modbus address of the sensor or identify which sensor the Display is connected to. At power up, the Display will search for all sensors on the bus.

Modbus Options																					
S	l	a	v	e		A	d	d	r	e	s	s					1	2	5		
	C	h	a	n	g	e		A	d	d	r						1	2	5		
	B	u	s		S	e	a	r	c	h							1	2	5		
>	M	o	d	b	u	s		E	n	a	b	l	e	d			Y	e	s		

Figure 175: Select the Modbus item

Select Modbus enabled to use the Display with a PLC or PC Program.

S	l	a	v	e		A	d	d	r	e	s	s					1	2	5		
	C	h	a	n	g	e		A	d	d	r						1	2	5		
>	B	u	s		S	e	a	r	c	h							1	2	5		

Figure 24: Bus search will find all available sensors on the bus

### 14 ADDITIONAL COMMANDS

#### 14.1 LONG MENU

The Long Menu adds several options to the Menus. This provides insight into some of the internal calibration values that are useful for troubleshooting.

To enable the Long Menu: Press the → and SELECT Key for at least 2 Seconds. You will see a notice that the Long Menu is Now Active. This will remain until the Display is powered off and on.

-	-	-	-	-	-	-	-	-	-	-	-	-	-	-	-	-	-	-	-
L	o	n	g	M	e	n	u	S	e	l	e	c	t	e	d				
-	-	-	-	-	-	-	-	-	-	-	-	-	-	-	-	-	-	-	-

Figure 25: Long menu notification (2 seconds)

Main Screen																			
C	H	L	8.	9	7	n	A	9	5	6	5								
p	H	7.	4	0															
O	R	P	8	0	3	P	S	U	3	2								L	
T	e	m	p	1	8														

Figure 26: Long menu enabled with L Indicator

Diagnostics																			
	M	o	n	i	t	o	r												
>	C	a	l	i	b	r	a	t	i	o	n	/	D	e	f	a	u	l	t
	L	o	g																

Additional Long Menu Enabled

This Menu selection is used to individually view and adjust individual slope and zero for three measurements: Chlorine, pH, and Conductivity. The screens are shown below.

>	S	e	t	P	H	/	C	H	L	/	C	O	N	D					
	S	e	t	t	o	D	e	f	a	u	l	t							

>	C	H	L	Z	e	r	o	&	S	l	o	p	e						
	C	o	n	d	u	c	t	i	v	i	t	y							
	p	H	Z	e	r	o	&	S	l	o	p	e							

>	C	H	L	Z	e	r	o												0	0	0	0		
	C	H	L	S	l	o	p	e											0	0	0	0	0	0
	C	H	L	.	1	4			2	8	2		n	A										

>	p	H		Z	e	r	o													0	0	3	0		
	p	H		S	l	o	p	e													-	0	5	5	4
	Z			1	6	3	.	1	4			p	H							7	.	8	9		
	S			-	5	0	.	6	3			m	v												

>	C	o	n	d	Z	e	r	o																		
	C	o	n	d	u	c	t	i	v	i	t	y														
	M	a	x		0		D	i	y		0															
	R	A	W		0		X		0		h	i	0													

### 14.2 CALIBRATION KEY CODE

Note: A Key Code can be activated to restrict access to calibration settings. To activate the key code, navigate:

**Menu | Measurement Options | Key Cde**

The Key Code option will be located just below the EOC Hold option on the second measurement options screen. Once activated, a code will be required to access the Calibration Menu.

When you select a Calibration Option, the following screen will appear. You will need to get the Key Code from your supervisor or have a qualified person perform the calibration operation. The Key Code consist of a series of keys pressed in order.

Enter Key Code																									
C	A	L	I	B	R	A	T	E	_	_	_	_													
E	N	T	E	R	K	E	Y	C	O	D	E														

Enter Key Code																								
C	A	L	I	B	R	A	T	E	*	_	_	_												
E	N	T	E	R	K	E	Y	C	O	D	E													

Enter Key Code																								
C	A	L	I	B	R	A	T	E	*	*	_	_												
E	N	T	E	R	K	E	Y	C	O	D	E													

Enter Key Code

C	A	L	I	B	R	A	T	E	*	*	*	_					
E	N	T	E	R	K	E	Y	C	O	D	E						

Enter Key Code

C	A	L	I	B	R	A	T	E	*	*	*	*					
E	N	T	E	R	K	E	Y	C	O	D	E						

Entering the Key Code will unlock the calibration menu and Sections 6 and 7 can be followed to adjust calibrations.

### 14.3 STOP FUNCTION

- A STOP command will halt measurement until the system is restored.
- Pressing MENU and BACK at the same time will enable the STOP cycle.
- Repeating the sequence will restart the cycle.

## 15 MANDATORY MAINTENANCE BY USER FOR SWN-P-HT2



### DANGER

Multiple hazards. Only qualified personnel must conduct the tasks described in this section of the document. Close ballast pipe valves to isolate sensor.

## 16 MAINTENANCE COMPONENTS FOR ALL SWN- MODELS

Table 1: Part Numbers for replacement

Quantity	PN	Description
1	WP-NH	Replacement Wear Kit (includes the below items)
1		Sensor cover
1		Impeller
15		Cleaning balls

Maintenance SWN-P-HT2	Frequency
Calibration Chlorine	Check every 6 months and recalibrate if level differs more than 20% from DPD reading
Replace Wear Parts	Every 24 months
Sensor Exchange- Replace motor assembly	Every 60 months



## 17 BIANNUAL MAINTENANCE (SWN-P+/SWN-P-HT2+)

1. Disconnect power from the sensor.
2. Make sure the ballast water system is shut down.
3. Isolate the sensor by closing all valves adjacent to the sensor.
4. Drain water from the ballast pipe section with the sensor.
5. Loosen the threaded retainer nut (Figure 18).
6. Remove sensor slowly to limit of lanyard assembly **\*DANGER\*\*** If sensor is removed without closing the valve, flooding can result.
7. Close the Hot Tap Valve.
8. Disconnect lanyard hooks from valve brackets.
9. Remove the sensor assembly from the valve.

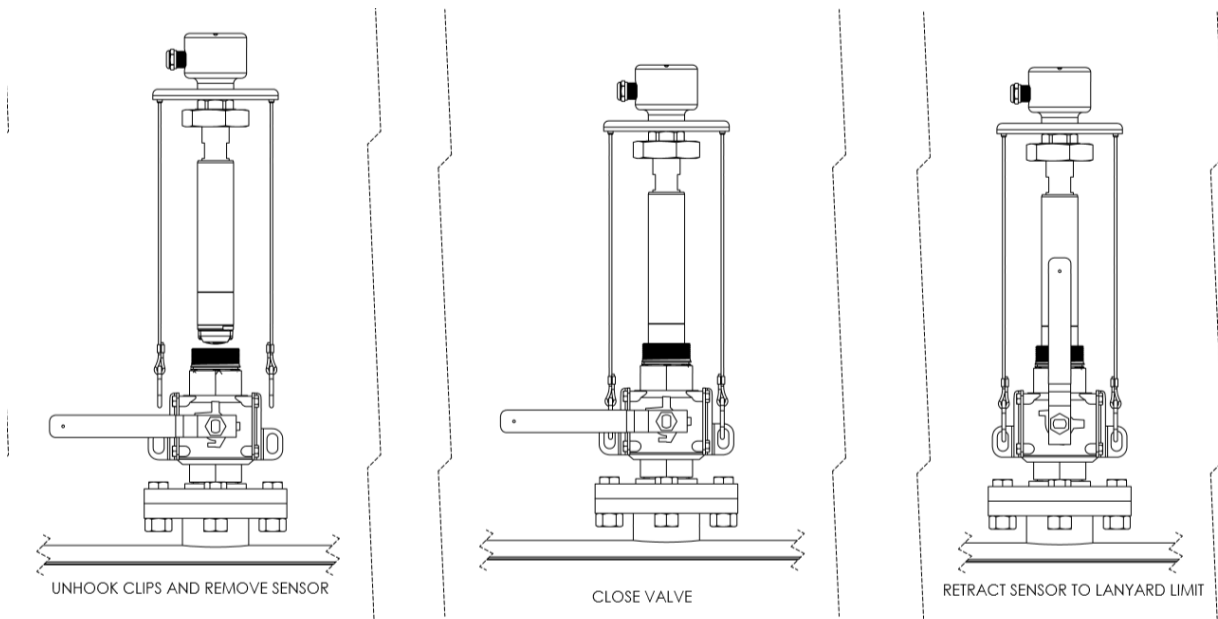



Figure 18: Remove sensor from Hot Tap Valve (Sequence Right to Left for removal)

	<b>CAUTION</b>
	Close all isolation valves before sensor removal.
	<b>CAUTION</b>
	Drain water from ballast pipe before sensor removal.

## 18 ANNUAL PH CALIBRATION CHECK

Place sensor into a solution of known pH value or pH buffer. If the sensor is reading more than 20% off from the reference value, permissible to complete a known value calibration. Allow the sensor to equilibrate for at least 3 minutes to the solution. Once pH measurements have stabilized, navigate to the **Calibration** menu and select **pH**. Select **Known Value**. Once in the known value screen, input the reference pH value and press **Select**. The sensor will calibrate to the reference value. If the sensor does not calibrate or an error is triggered, the pH probe may be defective or damaged. Contact Halogen Systems for a pH replacement kit and proceed to Section 20.

Calibration												
C	H	L										
C	O	N	D									
>	p	H										
4	-	2	0									

Calibrate pH												
>	K	n	o	w	n	V	a	l	u	e		
	B	u	f	f	e	r	C	a	l			
	p	H	R	e	s	e	t	D	e	f	a	u

## 19 BIANNUAL REPLACEMENT OF WEAR PARTS ALL EXCEPT EX- MODELS

### Tools Required:

1. Philips #1 Screwdriver
2. Isopropyl Alcohol (if available)
3. Lint free, clean cloth

### Kit Contents:

1. Cover Screws (x2)
2. Sensor Cover (x1)
3. Cleaning Beads (x20)
4. Impeller (x1)
5. Wear Ring (x1)

### Assembly Overview:

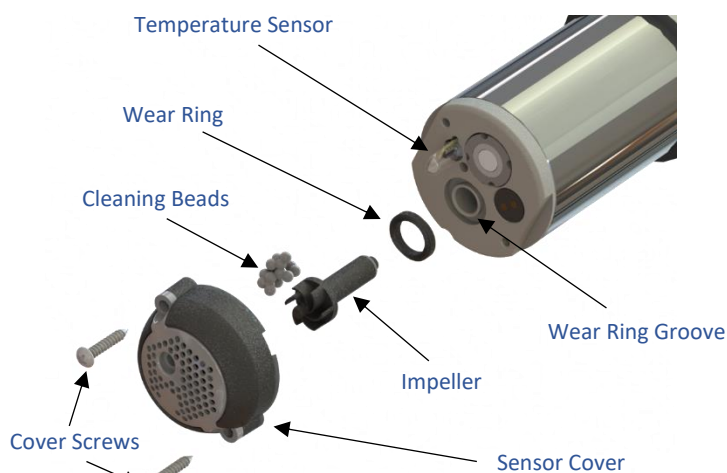

Figure 1: Exploded assembly - bottom view.

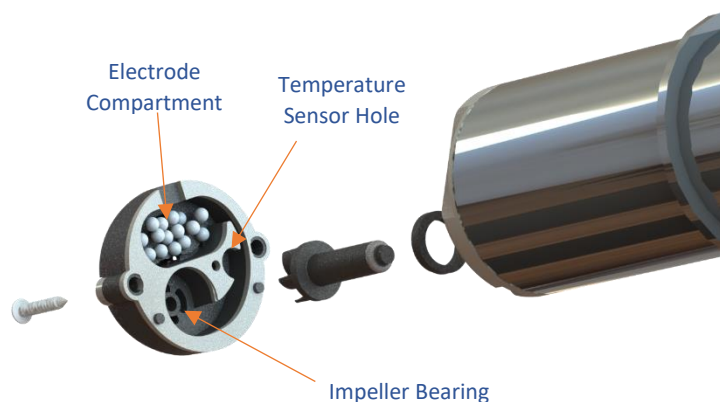

Figure 2: Exploded assembly - correct cleaning bead location.

**To remove wear parts:** Remove 2x cover screws from sensor cover. Maintain pressure on sensor cover and rotate sensor vertical. Remove sensor cover and screws from sensor end while keep sensor vertical. Remove impeller from impeller well. Impeller is magnetically coupled and should be removed easily. Remove wear ring. All removed parts can be discarded. If fouling present, permissible to clean sensor end with Isopropyl Alcohol and lint free cloth. Take care not to scratch electrode surface.

**To install new wear parts:** Remove parts from replacement wear kit. Install new wear ring into wear ring groove. Install new impeller into impeller well. Place 15 cleaning beads into sensor end cover (Figure 2). Beads must only be present in the electrode compartment. Align temperature sensor and impeller with respective holes in sensor cover. Lower sensor into sensor cover. Twist cover gently until sensor cover guide pins drop into sensor end. Holding sensor cover in place, insert, and tighten 2x cover screws until there is no gap between sensor cover gasket and sensor end. To prevent motor binding, do not overtighten.

**To function test sensor:** Power on sensor and verify that impeller spins freely. If impeller does not spin freely, loosen cover screws ¼ turn at a time until impeller can be heard spinning. Sensor can also be run in bucket with water to verify water stream from ejection port.

## 20 BIANNUAL pH SENSOR REPLACEMENT SWN-P-HT2+ AND SWN-P+

1. Use Halogen Repair Tool (included in KITS-0001) and insert prongs into recess in pH sensor (Figure 19 and Figure 20).
2. Rotate sensor counterclockwise (CCW) to unthread it (Figure 21).
3. Remove the old pH sensor and replace it with the new one (Figure 22).
4. Upon Startup, recalibrate pH using the buffer calibration option.

	K	n	o	w	n		V	a	l	u	e													
>	B	u	f	f	e	r		C	a	l														
	p	H		R	e	s	e	t		D	e	f	a	u	l	t								

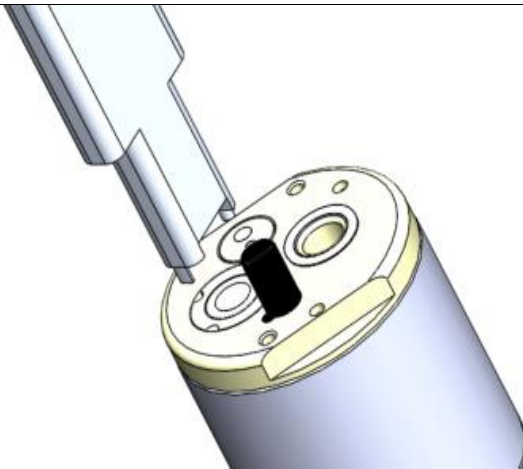

Figure 19: Use Halogen tool and insert prongs into the recess on the pH sensor.

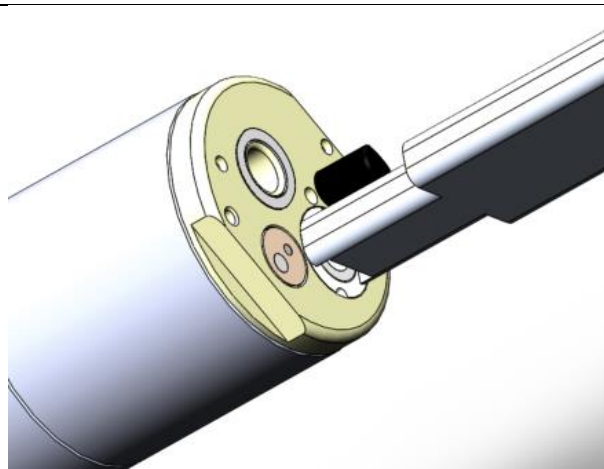

Figure 20: Insert prongs flush with pH Sensor.



Figure 21: Unthread the sensor by twisting counterclockwise (CCW).

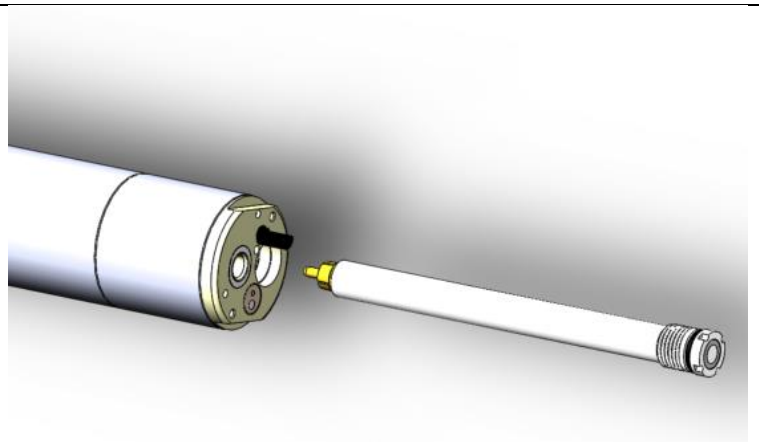

Figure 22: Remove the pH Sensor and discard. Replace with a new one. Make hole is wiped clean. Replacement sensor has silicone grease and an o-ring applied.

## 21 BI<sup>ANNUAL</sup> CALIBRATE CONDUCTIVITY

Recalibration of conductivity is usually unnecessary. If calibration is required, one of two methods can be used:

### Method 1

1. Use a Conductivity Standard between 12,880 $\mu$ S from a laboratory supply.
  - a. Cole Parmer- <https://www.coleparmer.com/p/oakton-conductivity-and-tds-standards/14688?Ntt=conductivity+standard>
  - b. Hanna Instruments- <https://www.hannainst.com/hi7030I-c.html>
2. Remove the sensor from the ballast pipe or side stream chamber.
3. Add the conductivity solution to a suitable container to a depth of at least 2.5 cm (1 in).
4. Insert the sensor head into the container.
5. Wait 3 cycles for stability.
6. Use the Recalibration Menu Sequence below to enter the new calibration.
  - a. The conductivity value must be entered as  $\mu$ S/cm.
7. Once you are at the KNOWN LEVEL screen (Figure 32), press SELECT to edit the value. Move the cursor using the  $\leftarrow$  $\rightarrow$  buttons and the  $\uparrow$  $\downarrow$  buttons to increment or decrement the value for each digit.
8. Press SELECT when finished to store the value.

### Method 2

1. Use a conductivity meter to obtain the conductivity of the water in the ballast pipe.
2. Do not calibrate if the conductivity is below 10,000  $\mu$ S.
3. Follow steps 5 through 8 above to recalibrate with the new value.

### Recalibration Menu Sequence

MENU | Calibration | COND | COND Known

C	H	L																	
>	C	O	N	D															
	p	H																	
	4	-	2	0															

Figure 23: Select COND from the MENU

<b>COND</b>																			
>	C	o	n	d		K	n	o	w	n					1	2	5	0	0

Figure 24: Enter Cond Known Value

## **22 LIMITED WARRANTY**

Halogen Systems warrants its products against material workmanship defects for a period of one year from the date of shipment.

In the event that a defect is discovered during the warranty period, Halogen Systems agrees, at its option, to repair or replace the defective product. Any product repaired or replaced under this warranty will be warranted only for the remainder of the original product warranty period.

Products may not be returned without authorization from Halogen Systems. To obtain authorization, please call Halogen Systems for a return material authorization number.

Limitations:

This warranty does not cover:

- 1) Damage caused by misuse, neglect (lack of appropriate maintenance), alteration, accident, or improper application or installation.
- 2) Damage caused by any repair or attempted repair not authorized by Halogen Systems.
- 3) Any product not used in accordance with the instructions furnished by Halogen Systems.
- 4) Damage caused by acts of God, natural disaster, acts of war (declared or undeclared), acts of terrorism, work actions, or acts of any governmental jurisdiction.
- 5) Freight charges to return merchandise to Halogen Systems.
- 6) Travel fees associated with on-site warranty repair.

This warranty is the sole expressed warranty made by Halogen Systems in connection with its product. All other warranties, whether expresses or implied, including without limitation, the warranties of merchantability and fitness for a particular purpose, are expressly disclaimed.

The liability of Halogen Systems shall be limited to the cost of the item giving rise to the claim. In no event shall Halogen Systems be liable for incidental or consequential damages.

This warranty is the sole and complete warranty for Halogen Systems. No person is authorized to make any warranties or representations on behalf of Halogen Systems.

Halogen Systems reserves the right to change or modify this warranty at any time.

## 23 REVISION HISTORY

DOCUMENT Version	REVISION DATE	REVISION DESCRIPTION
OM01-4.0	6/30/2020	Initial Release
OM01-4.1	12/30/2020	Change DPD Instruction to Lovibond MD100 from Hach colorimeter Struck calibration limit below 2 ppm
OM01-4.2	3/6/2021	Changed specification to 0 (non-freezing) to 40°C. (from 35°C) Changed salinity to 0.2 to 38 PSU (from 34)
OM01-4.2.2	5/7/22	Change Chlorine range from 0- to 10 ppm to 0 to 20 ppm and add DoC. Changed procedure to use DPD1 and DPD3.
OM01-4.2.3	9/15/22	Added menu option to enable 0.00 resolution for chlorine level.
OM01-4.2.4	10/3/2022	Changed 34 error code to 33 for 733 PCB. Changed minimum sample specification from 0.2 to 0.0 PSU (<150 µS conductivity) and from 0°C to -2°C
OM01-4.2.5	1/3/2023	Update Specifications to reflect DNV TA.
OM01-4.2.5	2/23/2023	Formatting updated. Wear part (WP-NH) and pH kit (KITS-0001) part numbers updated. Added models SWN-PS (+). WP-NH and Known pH Check instructions updated. CE & UKCA conformity statements added. DNVGL-CG-0339 updated to August 2021 revision.

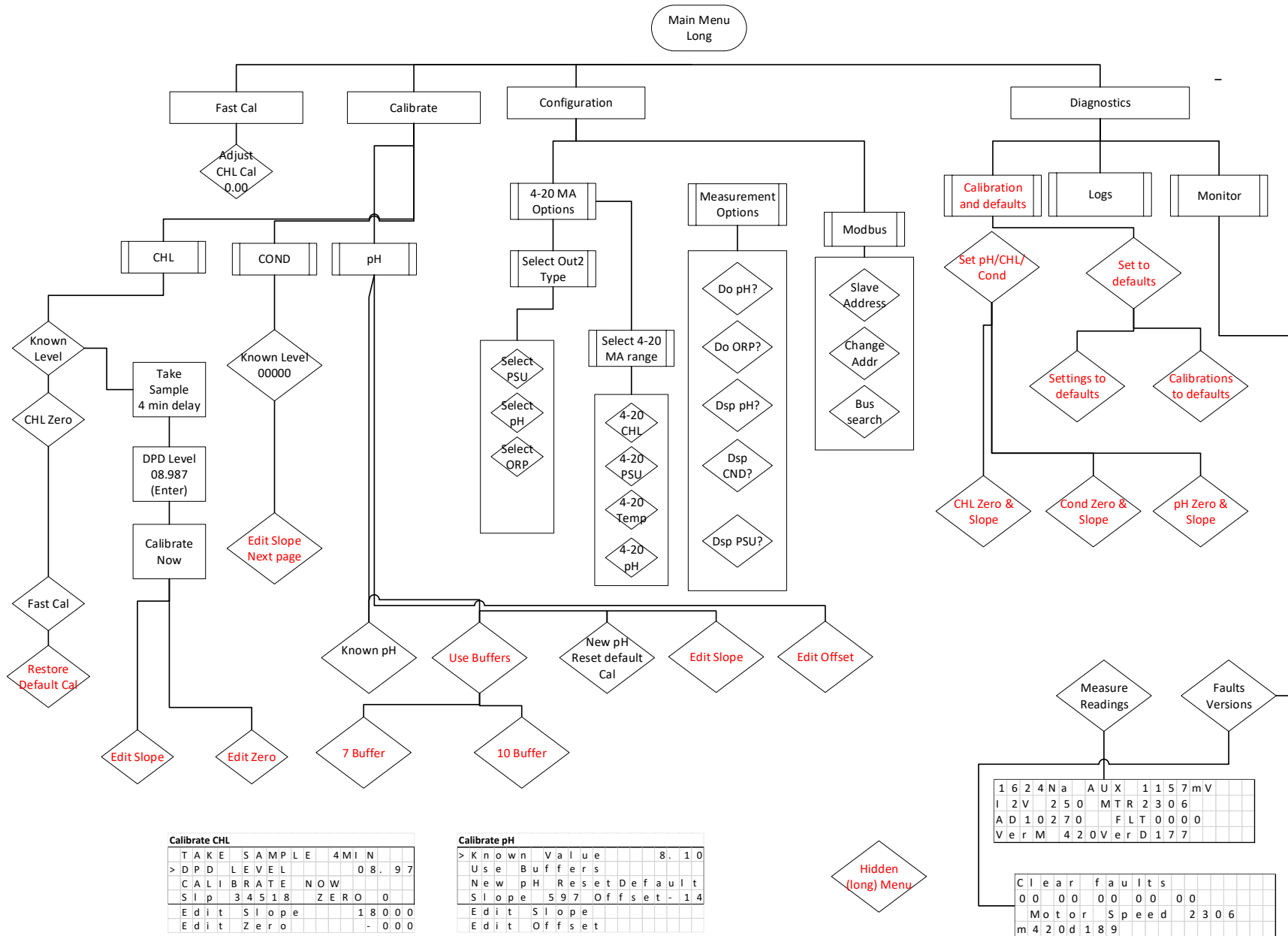

To enable the Long Menu: Press the **➔** and **SELECT** Key for at least 2 Seconds. You will see a notice that the Long Menu is Now Active. This will remain until the Display is powered off and on.